

PART NO.	"A"	"B" REF	"C" HOLDING DIAMETER	"D" REF
HURC1-2-01	.20 [5.1]	.49 [12.4]	1/8 [3.2]	.17 [4.3]
HURC1-3-01	.24 [6.1]	.56 [14.2]	3/16 [4.8]	.24 [6.1]
HURC1-4-01	.27 [6.9]	.62 [15.7]	1/4 [6.4]	.30 [7.6]

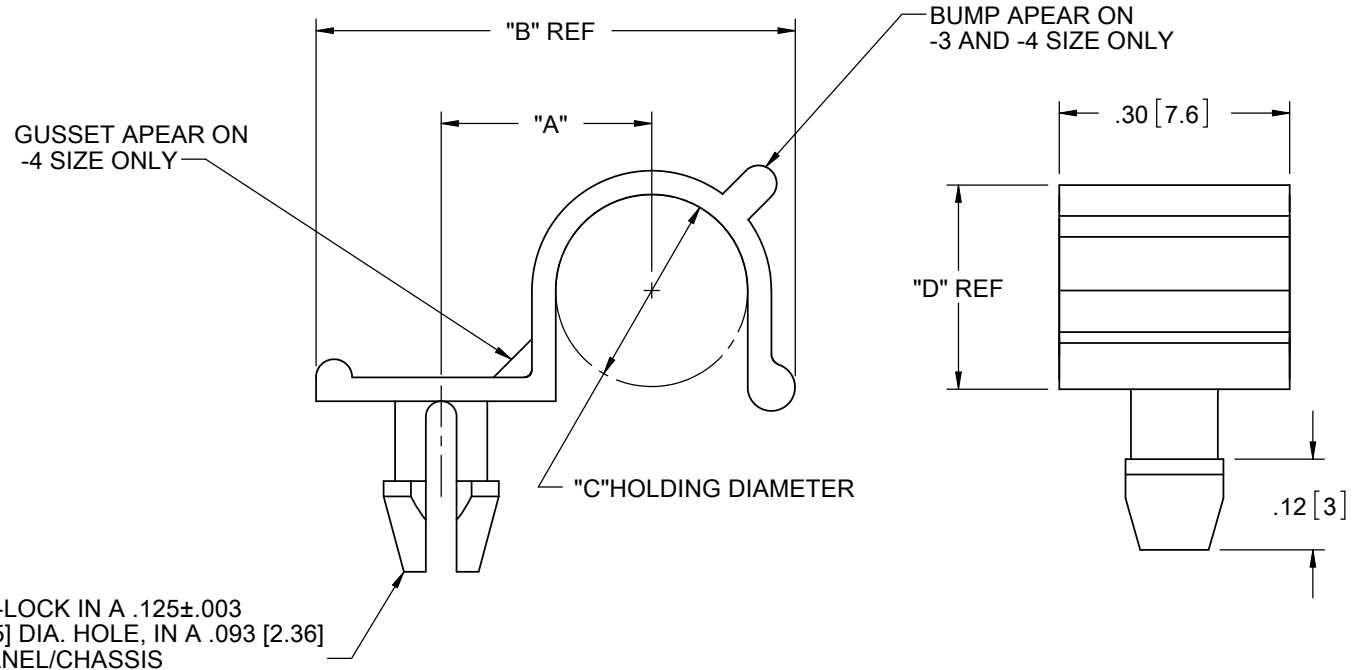

**NOTES:**

1. MATERIAL: NYLON 6/6 UL 94 V-2 (RMS-01).  
 NYLON 6/6 UL 94 V-0 (RMS-19) AVAILABLE  
 BY SPECIAL ORDER ONLY
2. COLOR: NATURAL.

REV.	DESCRIPTION	ENGR.	DATE
C	SEE CO 200201 FOR CHANGES	S.K.	06/10/08
B	SEE CO 200169 FOR CHANGES	S.K.	04/29/08
A	CHANGES FILE NO.	S.M.	05/31/01

TITLE: "HALF-U" ROUTING CLIP						DWG IN IN [MM]	
CREATED USING SOLIDWORKS TOLERANCES UNLESS NOTED .XX=±.010 .XXX=±.005 FRAC.=±1/64 ANG.=±1°		FILE #: HURC1 SHEET: 1 OF 1 SHEET SIZE: A RE: RICHCO, INC.	DWN: SK DT: 04/29/08	APP: S.J. CHKD: S.K.	FINAL PART # <b>SEE TABLE</b>		PRINT TYPE <b>CA</b>
RICHCO, INC. ENG@RICHCO-INC.COM (773) 539-4060							